

# USB2 - CCD 2048A - 200

Complete medium speed, low noise ccd linescan camera system

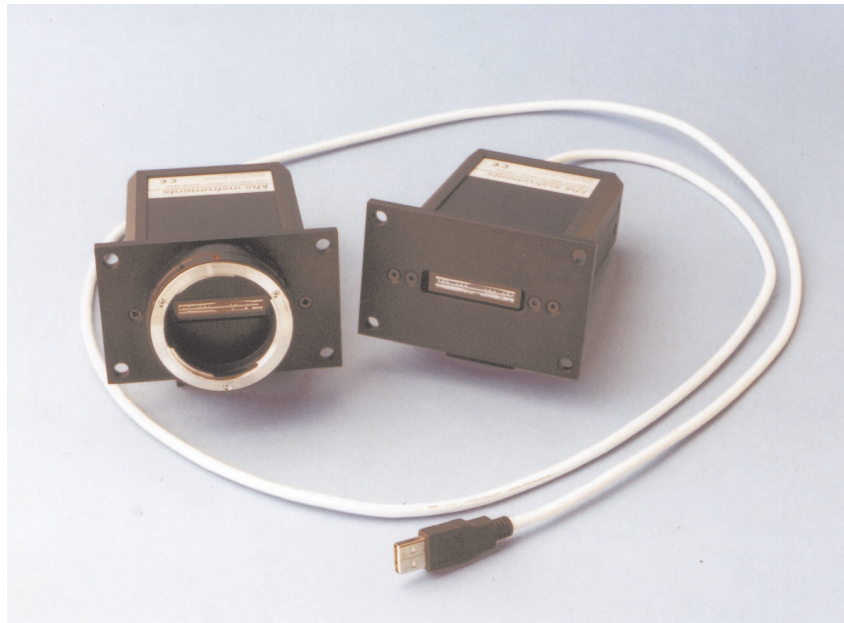

## Key Features:

- CCD-line scan camera system.
- 2048 Pixels low noise.
- External and internal trigger.
- Start of frame output.
- Optional Contax lens mount.
- Drivers for W98 / W2K/ XP/ Labview.

## Applications:

- Spectroscopy.
- Portable applications
- Position detector.

## Overview:

The USB-CCD 2048 is an easy to use, complete ccd linescan camera system. It includes a low noise ccd linescan camera with USB 2.0 interface. Additional components are not required.

The USB2-CCD was designed for low speed applications with the need of high sensitivity and low noise, like spectroscopy or position detection of a moving low power laser beam.

## Hardware:

The USB2-CCD camera head includes the complete CCD-timing with signal conditioning (CDS), a precision 12 Bit ADC and an USB 2.0 interface.

The camera head is powered by the USB-bus. Additional power-supplies are not required. The USB2-CCD provides optional start of scan output and an input for external triggering.

The camera head can be equipped with an optional Contax (other manufacturer upon request) compatible lens mount.

khs instruments

## Software

The USB2-CCD linescan camera system is shipped with a software for Windows 98, Windows 2000 and XP.

The software includes a DLL to provide an interface to other software and an user software. Drivers for Labview are available upon request.

The user software includes various modes to edit the x/y scales and units, a run mode to observe the sensors's signal, signal processing functions like averaging, binning and x/y zoom and a function to subtract a reference from the actual scan. To get a zero baseline at once, the reference can be loaded from the actual scan. This function works with floating point accuracy.

The two averaging modes provide functions for further reducing the signal to noise ratio.

The integer accumulation mode performs a fast accumulation of several scans.

The averaging mode calculates the running mean of consecutive displayed scans. This floating point function performs (with the excellent integral linearity of the ADC) a baseline stability of 1/2 LSB. (This is possible for very slow processes only.)

To provide a stable display of non-repetitive signals (like a laser beam crossing the CCD-sensor chip), a software trigger was included. Only these scans are displayed (and averaged) which pixels exceeding a selectable threshold .

The view modus provides functions to read and print stored files from disk. The file format for stored data is ASCII, to facilitate the data transfer to other programs like Excel.

## Mechanical Dimension

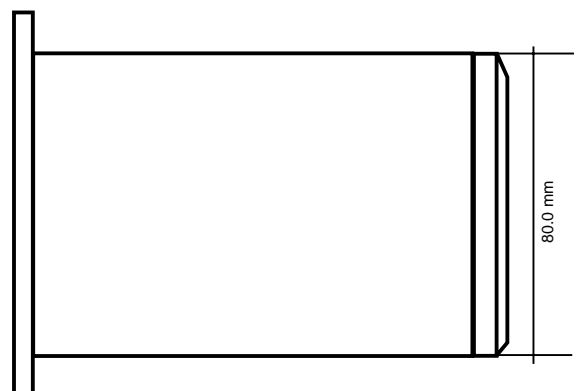
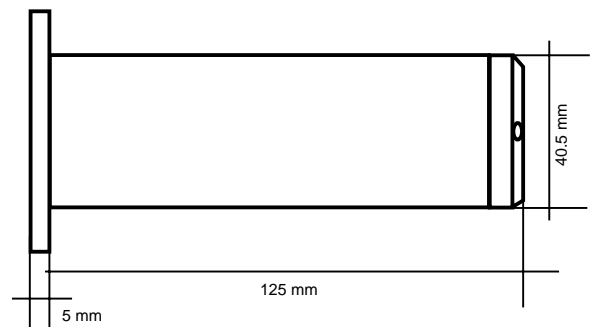
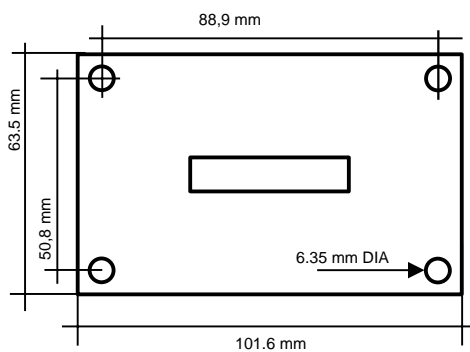

## Specifications

### Detector array:

Number of pixels: 2048  
 Pixel size: 14  $\mu\text{m}$  x 200  $\mu\text{m}$   
 Spectral range: < 400nm..1000nm  
 Sensitivity nonuniformity: < 10% ss  
 Sensitivity (660 nm): 333 E3 counts / (lx sec)  
 Saturation exposure: 0.01 lx sec

### System & detector:

Signal/Noise pp: about 1000 : 1.  
 Signal / Noise rms about 10000 : 1.  
 Exposure Time: 3.5 ms to 1,0 s.  
 Framerate: about 280 lps.

### System requirements:

Operating system: Win 98 / W2K / XP.  
 Disk: 300 KB free.

### USB interface:

USB: 1.1.  
 Required Current: 500 mA.

**Optional:**  
 Trigger: Input TTL.  
 Start of scan: Output TTL.

### Software:

Software includes: User software,  
 DLL interface,  
 Driver for Labview  
 upon request.

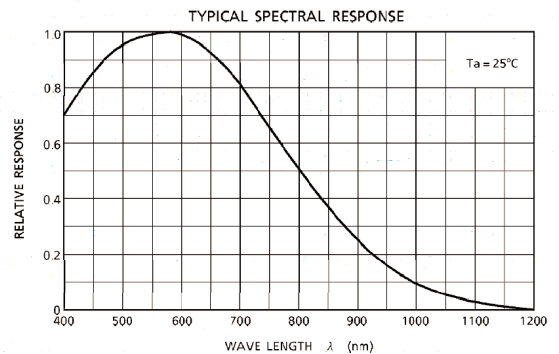

### User software:

X scale edit: Enter start and stop.  
 Enter the values at two cursor positions.

Y scale edit: Enter start and stop.  
 Enter the values at two cursor positions.

X / Y unit edit: Enter units.

Averaging: Integration of several scans (up to 15).  
 Running mean of n consecutive scans.

Binning: Up to 64 pixels.

Display options: Display actual scan.  
 Load reference from actual scan and display scan minus reference.  
 Set reference to zero.

Data operations: Write to disk.  
 Write consecutive scans to disk.  
 Read from disk.  
 Print scan.