

LCCD 2048A - 200

Complete low cost
ccd linescan
camera

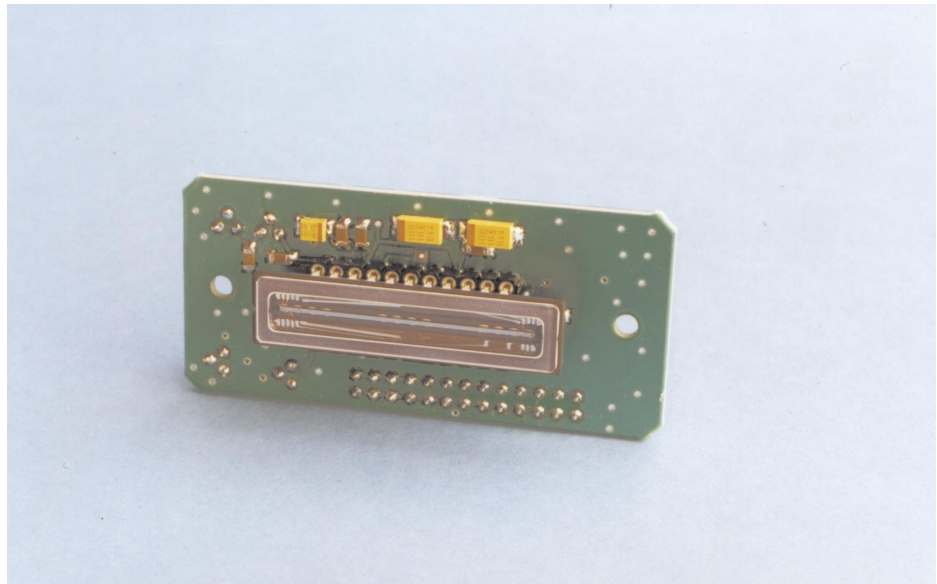

Key Features:

- Stand alone CCD-line scan camera.
- All clock signals included.
- Analog output with pixel clock.
- Start of frame output.
- Selectable exposure time.
- Low cost

Applications:

- Spectroscopy.
- Industrial imaging.
- Bar code reader.
- Position detector.
- Prototyping.

Overview:

The LCCD 2048 is an easy to use, complete ccd linescan camera on a single 67.5 mm x 31.5 mm sized printed circuit board.

For operation the LCCD requires 5 V only, additional logic is not required.

To provide more flexibility the LCCD has an interface to control exposure time and pixel clock. All inputs are connected to internal pull up resistors, so they can left unconnected if not required.

Hardware:

The LCCD linescan camera includes the CCD-linescan sensor with all required CCD-timing signals including pixel clock and exposure control.

The digital interface provides user selectable pixel clock and exposure time. An output for pixel clock and start of frame facilitates the operation with an additional frame grabber.

With an additional oscilloscope the LCCD-2048 converts to a complete very low cost CCD-linescan camera with display. (See the application on the last page).

khs instruments

Camera Interface

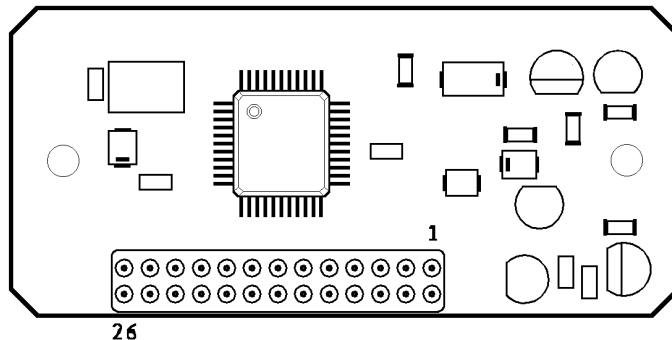

Connections:

Signal	Pin	Pin	Signal
GND	1	2	CCD
GND	3	4	GND
GND	5	6	GND
GND	7	8	VDD (+ 12 V)
VCC	9	10	GND
SOS	11	12	nc
PCLK	13	14	nc
nc	15	16	Reset
ts2	17	18	ps2
ts1	19	20	ps1
ts0	21	22	ps0
te	23	24	pe
nc	25	26	SH

Pinout description:

Pin Name	Pin Type	Pin Description
GND	Power	Power Ground.
VCC	Power	Power + 5 V.
VDD	Power	Power +12 V.
CCD	Out	Analog output.
SOS	Out	Start of scan output, low active.
PCLK	Out	Pixelclock output, low active.
ts0..ts1	In	Exposure control.
te	In	Exposure control external.
ps0..ps1	In	Pixelclock control.
pe	In	Pixelclock external.
Reset	In	CCD asynchron reset.
SH	In	Sample/Hold enable hi active.
nc	nc	Do not connect!

All inputs: 50 K pull up to VCC.

Exposure timer control*:

*ps0..ps2=1

ts2	ts1	ts0	exposure time
1	1	1	810 μ s
1	1	0	1.6 ms
1	0	1	3.2 ms
1	0	0	6.4 ms
0	1	1	12.8 ms
0	1	0	25.6 ms
0	0	1	51.2 ms
0	0	0	external

Pixelclock control:

ps2	ps1	ps0	pixel clock
1	1	1	2 MHz
1	1	0	1 MHz
1	0	1	500 kHz
1	0	0	250 kHz
0	1	1	125 kHz
0	1	0	62.5 kHz
0	0	1	31.2 kHz
0	0	0	external/4

DC characteristics:

Output low voltage (8 mA)	0.4V
Output high voltage (-4 mA)	2.4V
Input pullup current	-0.15 mA
Input low Voltage (max)	0.8 V
Input high voltage (min)	2.0V

Power requirements:

+ 5 V 200 mA, + 12 V 100 mA

Camera Timing Overview

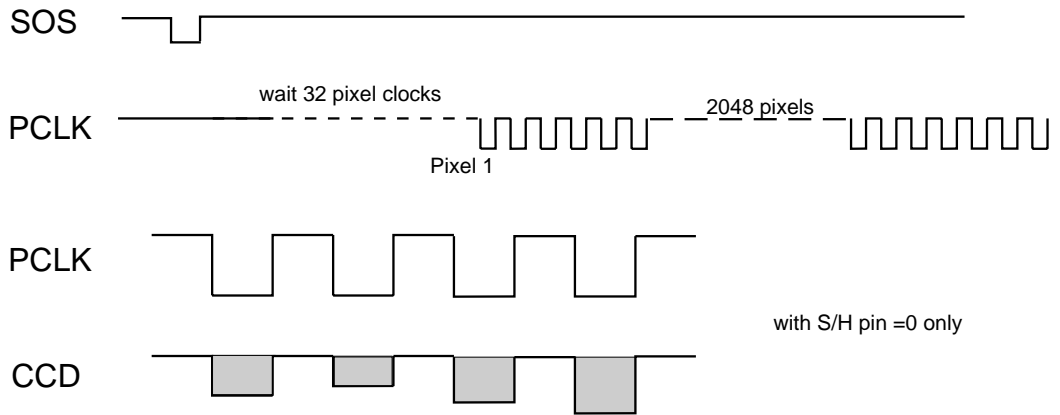

Mechanical Dimension

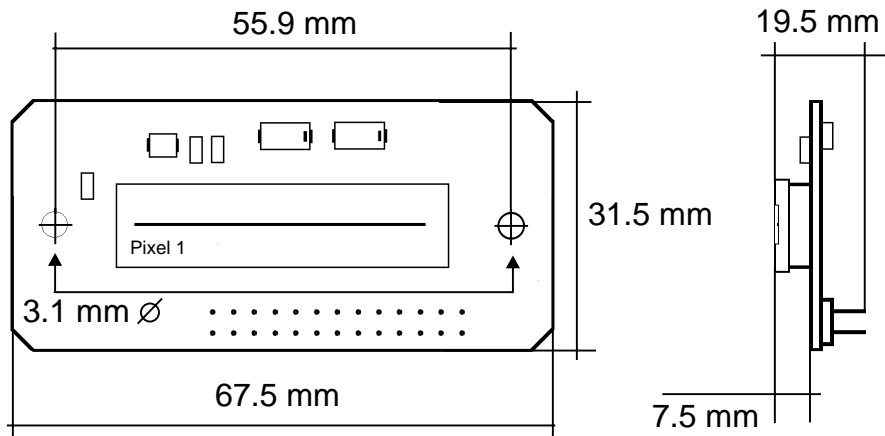

Sensor

Detector Array:

Number of pixels:	2048
Pixel size:	14 μm x 200 μm
Spectral range:	< 400nm..1000nm
Sensitivity nonuniformity:	< 10% (typ. 5%) ss
Sensitivity (660 nm):	1800V / (lx sec)
Saturation exposure:	0.004 lx sec
Analog output:	-0.7 to 9 V

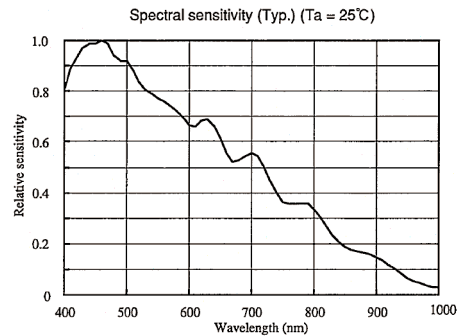

Absolute Maximum Ratings

VCC Supply voltage	- 0.5 V to + 6 V
Input voltage applied	- 0.5 to Vcc + 0.5 V
Digital output current	0 to 5 mA
CCD output current	0 to -10 mA
Storage temperature	- 20 to 150 °C
Operating temperature	0 to 50 °C

Application

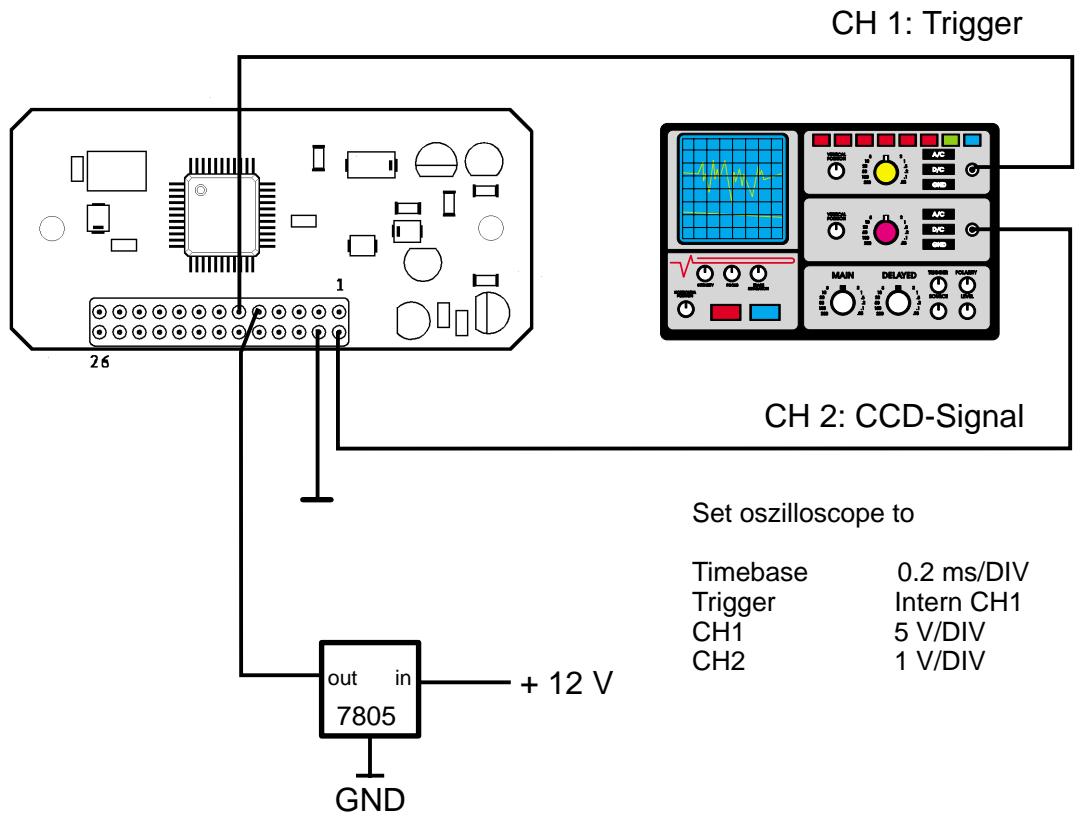

Fig. 1 Test circuit