

USB - CCD 2048A - 14

Complete slow scan, low noise ccd linescan camera system

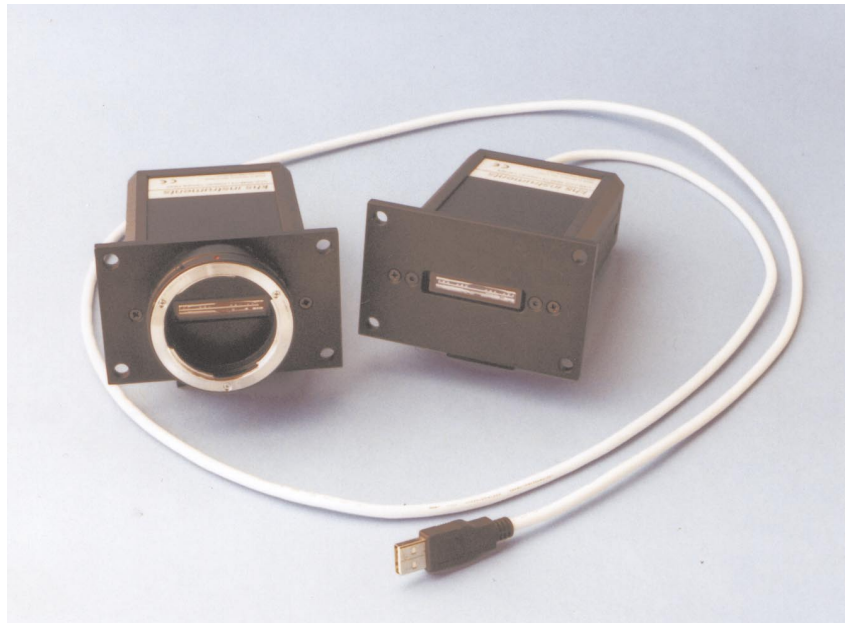

Key Features:

- CCD-line scan camera system.
- 2048 Pixels low noise.
- External and internal trigger.
- Start of frame output.
- Optional Contax lens mount.
- Drivers for Win 98 / 2000 / Labview.

Overview:

The USB-CCD 2048 is an easy to use, complete ccd linescan camera system. It includes a low noise ccd linescan camera with USB 1.1 interface. Additional components are not required.

The USB-CCD was designed for low speed applications with the need of high sensitivity and low noise, like spectroscopy or position detection of a moving low power laser beam.

Applications:

- Spectroscopy.
- Portable applications
- Position detector.

Hardware:

The USB-CCD camera head includes the complete CCD-timing with signal conditioning (CDS), a precision 12 Bit ADC and an USB 1.1 interface.

The camera head is powered by the USB-bus. Additional power-supplies are not required. The USB-CCD provides optional start of scan output and an input for external triggering.

The camera head can be equipped with an optional Contax (other manufacturer upon request) compatible lens mount.

khs instruments

Software

The USB-CCD linescan camera system is shipped with a software for Windows 98 and Windows 2000.

The software includes a DLL to provide an interface to other software and an user software. Drivers for Labview are available upon request.

The user software includes various modes to edit the x/y scales and units, a run mode to observe the sensors's signal, signal processing functions like averaging, binning and x/y zoom and a function to subtract a reference from the actual scan. To get a zero baseline at once, the reference can be loaded from the actual scan. This function works with floating point accuracy.

The two averaging modes provide functions for further reducing the signal to noise ratio.

The integer accumulation mode performs a fast accumulation of several scans.

The averaging mode calculates the running mean of consecutive displayed scans. This floating point function performs (with the excellent integral linearity of the ADC) a baseline stability of 1/2 LSB. (This is possible for very slow processes only.)

To provide a stable display of non-repetitive signals (like a laser beam crossing the CCD-sensor chip), a software trigger was included. Only these scans are displayed (and averaged) which pixels exceeding a selectable threshold .

The view modus provides functions to read and print stored files from disk. The file format for stored data is ASCII, to facilitate the data transfer to other programs like Excel.

Mechanical Dimension

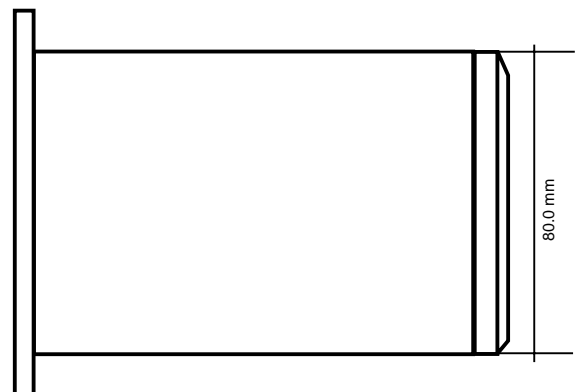
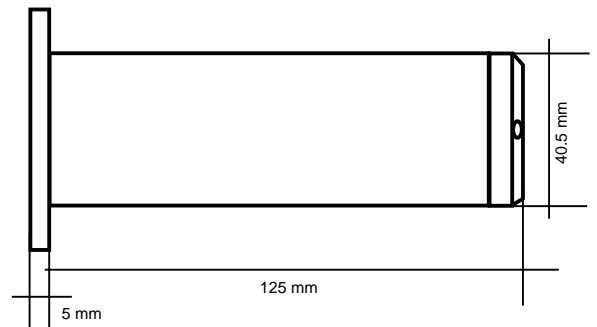
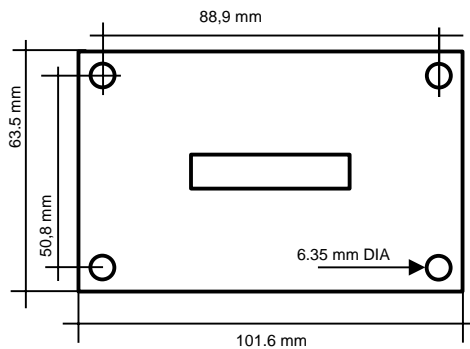

Specifications

Detector array:

Number of pixels: 2048.
 Pixel size: 14 μm x 14 μm .
 Spectral range: < 400nm..1000nm.
 Sensitivity nonuniformity: < 8% (typ. 2%) ss.
 Sensitivity (660 nm): 6.8 E4 counts / (lx sec).
 Saturation exposure: 0.060 lx sec.

System & detector:

Signal / Noise pp: about 1000 : 1.
 Signal / Noise rms: about 10000 : 1.
 Exposure Time: 20 ms to 1,0 s.
 Framerate: 50 fps.

System requirements:

Operating system: Win 98 / 2000.
 Disk: 300 KB free.

USB interface:

USB: 1.1.
 Required Current: 500 mA.

Optional:
 Trigger: Input TTL.
 Start of scan: Output TTL.

Software:

Software includes: User software,
 DLL interface,
 Driver for Labview
 upon request.

Spectral sensitivity characteristics
 (Standard characteristics)

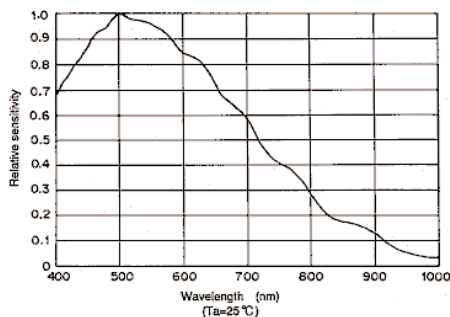

User software:

X scale edit: Enter start and stop.
 Enter the values at two
 cursor positions.

Y scale edit: Enter start and stop.
 Enter the values at two
 cursor positions.

X / Y unit edit: Enter units.

Averaging: Integration of several
 scans (up to 15).
 Running mean of n
 consecutive scans.

Binning: Up to 64 pixels.

Display options: Display actual scan.
 Load reference from
 actual scan and display
 scan minus reference.
 Set reference to zero.

Data operations: Write to disk.
 Write consecutive
 scans to disk.
 Read from disk.
 Print scan.